



## Tagalong™ Jumbo On-Seat Booster Care & Use Guide

Thank you for purchasing the Solvit Tagalong™ On-Seat Booster. This product is designed to let pets up to 30 lbs ride comfortably in a vehicle thus reducing driver distraction and improving safety.

To assemble, un-bundle the plastic pieces and locate the Front Strut, Left Wall and Right Wall.

**IMPORTANT:** When assembling all plastic pieces, keep the smooth side of each piece facing “in” and the side with circles facing “out”. Insert tab A on Front Strut into slot A in Left Wall and slide Front Strut in the direction of the arrow until tab A is in the fully locked position.

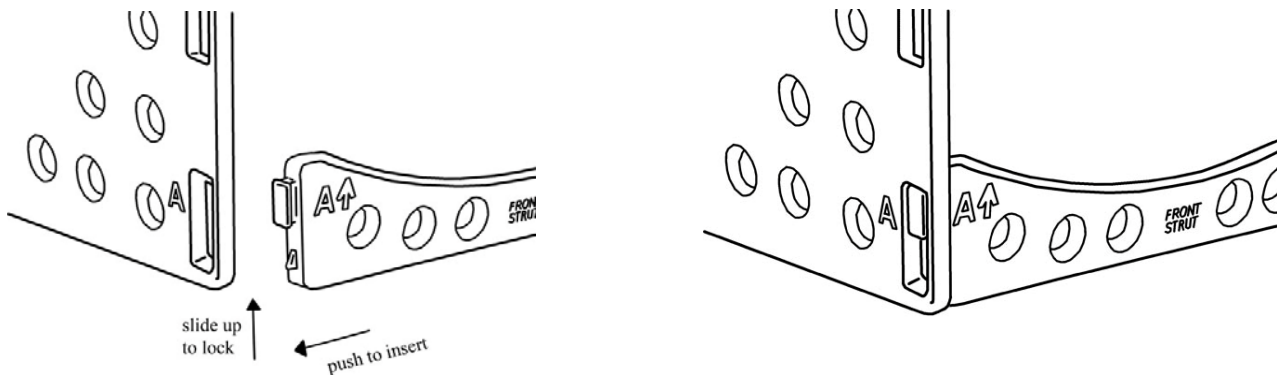

Repeat this procedure to lock tab B on Front Strut into slot B on Right Wall, and to lock tabs C and D on Rear Strut into slots C and D on the Left and Right Wall sections.

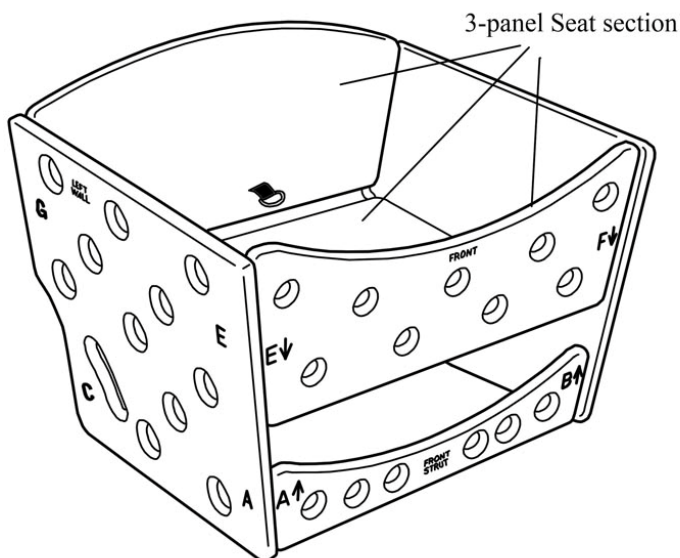

The Seat section is a three-panel piece that was folded in a “Z” shape in the package. Before connecting to the Left and Right Wall sections, fold the Seat section into a “U” shape with the smooth sides facing “in”. Insert double-tab E on the front panel of the Seat section into slot E on the Left Wall and slide to lock. Repeat for tab G then repeat for tabs F and H into the corresponding slots on the Right Wall.

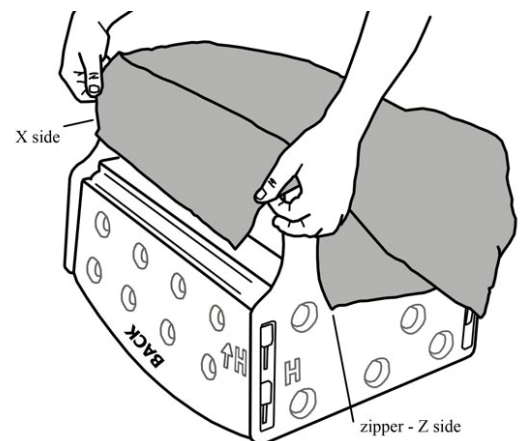

Place the assembled plastic frame upside-down on a clean surface. The Outer Fabric Shell has a zipper and small tags marked “Z” (next to zipper) and “X” (on opposite seam). With zipper in the fully open position, slide the fabric shell over the plastic frame so the “Z” seam aligns with the “H” corner at the back of the plastic frame and the “X” seam aligns with the “G” corner.

Pull the sides of the fabric shell down all four sides of the plastic frame until the rectangular bottom panel of the fabric shell aligns with the rectangle at the bottom of the plastic frame.

Turn the entire assembly right-side-up and pull the fabric shell up and over the top edges of the plastic seat, and close the zipper. The seat should now look like the image at right and the two seat belt slits in the fabric shell should align with the holes in the plastic frame.

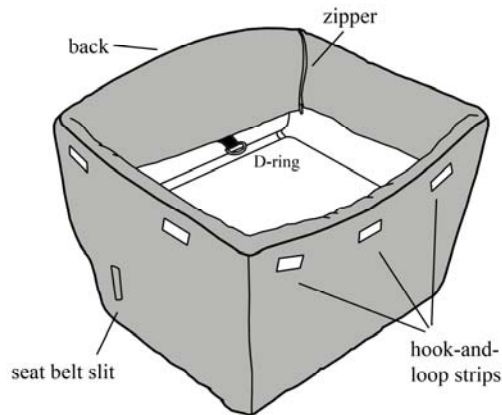
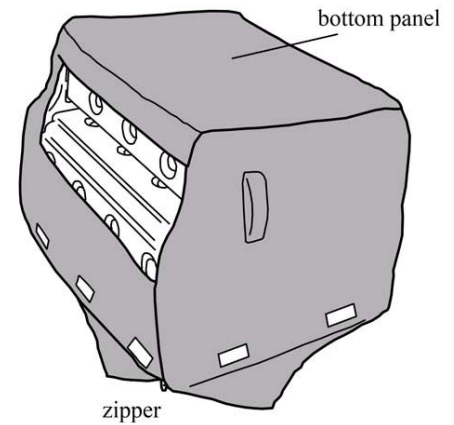

The underside of the Inner Fabric Liner also has two small tags marked “X” and “Z”. Insert the inner liner into the seat portion of the plastic frame so the “X” and “Z” seams on the inner liner align with the “X” and “Z” seams on the outer shell. Fit the upper edge of the fabric liner over the rear wall of the plastic frame and fasten the loop tape pieces on the inner liner with the hook tape pieces on the outer shell.

Pass the metal D-ring, which is fastened to the inside back panel of the plastic frame, through the small slit sewn into the lower edge of the back panel of the fabric liner. Attach the safety leash to the D-ring. Fit the upper edges of the other three sides of the fabric liner over the edges of the plastic frame and fasten the hook and loop tape strips for each side. Finally, insert the reversible pillow with the desired side facing up.

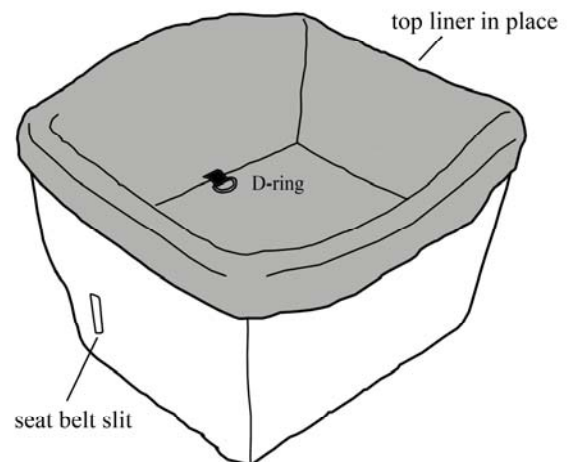

To install in vehicle, place the booster on the vehicle seat and pass the seat belt through the holes in the fabric and plastic frame on one side of the booster.

Thread the seat belt all the way through the frame and out the holes on the opposite side, and buckle. Place your pet in the booster, attach the leash, and it's ready to go! For multiple pets, extra leashes are available – contact Solvit customer service at the number below.

**Cleaning:** Fabric pieces can be machine washed in cold - machine dry without heat or line dry.

**Warranty:** The Tagalong On-Seat Booster is warranted to be free from defects in materials or workmanship for a period of one (1) year from the date of purchase. A copy of the original sales receipt is required for warranty issues.

Solvit Products is dedicated to offering innovative solutions to improve pets' quality of life. Please feel free to contact us with and questions, comments, or warranty issues. Thank you for your purchase!